

THIS COPY IS PROVIDED ON A RESTRICTED BASIS AND IS NOT TO BE USED IN ANY WAY DETRIMENTAL TO THE INTERESTS OF PANDUIT CORP.

PART NO.	MATERIAL	MAX. BUNDLE DIA [mm]	LENGTH ±.1 (2)
MS4W50T15-L4	304	4" [102]	18.0" [457]
MS4W50T15-L6	316		
MS6W50T15-L4	304	6" [152]	24.4" [620]
MS6W50T15-L6	316		
MS8W50T15-L4	304	8" [203]	30.7" [780]
MS8W50T15-L6	316		
MS10W50T15-L4	304	10" [254]	37.0" [940]
MS10W50T15-L6	316		

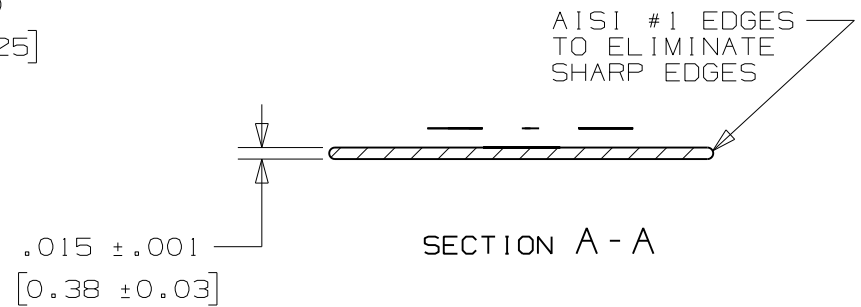
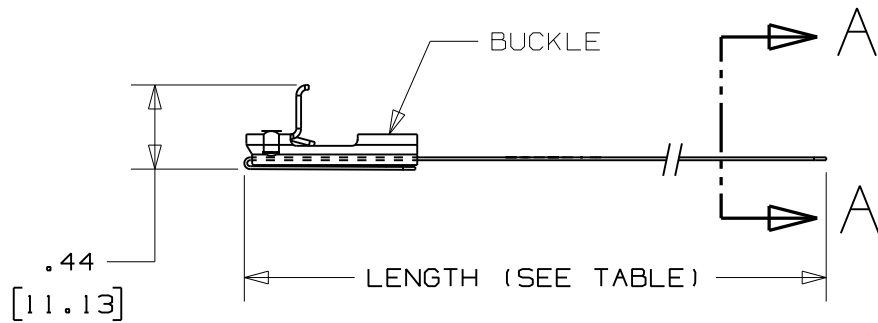
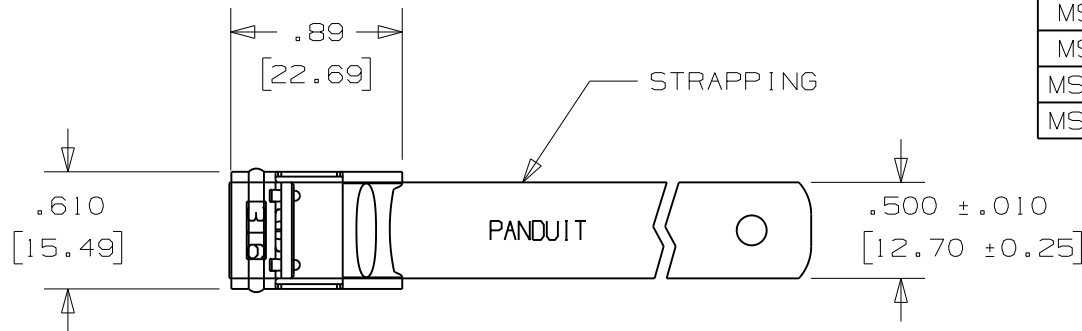

- NOTES: 1. APPLICATION TOOLS: BT2MS75, BT2HT
 2. ALL DIMENSIONS IN BRACKETS [] ARE MILLIMETERS.
 3. FOR MATERIAL SEE TABLE.
 4. TOLERANCES (UNLESS OTHERWISE SPECIFIED):
 .X ± .03 [.8]
 .XX ± .02 [.5]
 .XXX ± .01 [.25]

N41151BS_DC/01A

										TINLEY PARK, ILLINOIS METAL STRAPPING .500 [12.70] WIDE CUSTOMER DRAWING	
01A	10/08	JAMB	SKB	ORIG CAD FILE SPEC WAS S41151_01. NOTE 1: APPLICATION TOOL BT1HT REPLACED BY BT2HT							
01	11/06	MIM	SKB	#1 BODY EDGE WAS A #5 BODY EDGE				11155	CCH	JJB	
00	9/03	BRH	EJD	RELEASED							
REV	DATE	BY	CHK	DESCRIPTION				ECN #	PM	CUST	DRAWING NO.
											N41151BS_DC